



Journal Homepage: - [www.journalijar.com](http://www.journalijar.com)

## INTERNATIONAL JOURNAL OF ADVANCED RESEARCH (IJAR)

Article DOI: 10.21474/IJAR01/xxx

DOI URL: <http://dx.doi.org/10.21474/IJAR01/xxx>



### RESEARCH ARTICLE

#### EFFECT OF CAVITY RATIO ON HEAT TRANSFER BY FREE LOAD FROM HEATED PLATES UPWARD WITH CONSTANT HEAT FLUX

**Dr. Waleed Abdulhadiethbayah**

Specialist Trainer B, High Institute of Energy, Kuwait.

#### Manuscript Info

##### Manuscript History

Received: xxxxxxxxxxxxxxxxx

Final Accepted: xxxxxxxxxxxxx

Published: xxxxxxxxxxxxxxxxx

#### Abstract

Many engineering and industrial applications always seek to find ways to dissipate heat from heated surfaces used in these industries. As it is involved in the cooling of electronic parts and electrical transformers, as well as the design of solar collectors, in addition to being a process of heat exchange between hot surfaces and the fluids in contact with them. Since most electronic devices or their parts are cooled by removing the heat generated inside them by using air as a heat transfer medium and in a free convection way, and the fact that heat transfer by free convection occurs in many fields, so there were many studies that dealt with this topic. The free load is generated by the buoyant force (Bouncy force) As a result of the difference in the density of the fluid adjacent to the heated surface due to the difference in temperatures between the fluid and the surface. The laminar flow along surfaces has been extensively studied analytically [1,2,3,4] In the horizontal, inclined and vertical case, whether by constant heat flux or constant surface temperature, there are also many experimental studies of heat transfer by free convection from horizontal, inclined and vertical surfaces with constant heat flux or constant surface temperature [5,6,7,8]. Some experimental studies have also been conducted on heat transfer by convection from heated surfaces in the form of a disk (ring)The outcome of these studies was to extract an exponential mathematical relationship between the average of Nusselt number and the Kirchhoff number or Rayleigh number and the following formula:  $(Nu=C(Ra)^n)$  It is one of the most suitable formulas for heat transfer by free convection from heated surfaces in all its forms and over a wide range of Rayleigh number . It is noted that not all of these studies dealt with the study of the effect of the cavity ratio on heat transfer by free convection from square-shaped surfaces, which is the form that is more applied in electronic devices. Therefore, the current research means studying the rate of change in the average of Nusselt number, which represents a function of the rate of change in the rate of heat transfer by convection, as well as studying the thermal gradient above the surface, and this was done through using three hollow surfaces in proportions (0.25,0.5,0.75) of the total area.

Copy Right, IJAR, 2021,. All rights reserved.

**Corresponding Author:- Dr. Waleed Abdulhadiethbayah**

Address:- Specialist Trainer B, High Institute of Energy, Kuwait.

## Introduction:-

Many engineering and industrial applications always seek to find ways to dissipate heat from heated surfaces used in these industries. As it is involved in the cooling of electronic parts and electrical transformers, as well as the design of solar collectors, in addition to being a process of heat exchange between hot surfaces and the fluids in contact with them. Since most electronic devices or their parts are cooled by removing the heat generated inside them by using air as a heat transfer medium and in a free convection way, and the fact that heat transfer by free convection occurs in many fields, so there were many studies that dealt with this topic. The free load is generated by the buoyant force (Bouncy force) As a result of the difference in the density of the fluid adjacent to the heated surface due to the difference in temperatures between the fluid and the surface.

The laminar flow along surfaces has been extensively studied analytically [1,2,3,4] In the horizontal, inclined and vertical case, whether by constant heat flux or constant surface temperature, there are also many experimental studies of heat transfer by free convection from horizontal, inclined and vertical surfaces with constant heat flux or constant surface temperature [5,6,7,8].

Some experimental studies have also been conducted on heat transfer by convection from heated surfaces in the form of a disk (ring) The outcome of these studies was to extract an exponential mathematical relationship between the average of Nusselt number and the Kirchhoff number or Rayleigh number and the following formula:  $(Nu=C(Ra)^n)$  It is one of the most suitable formulas for heat transfer by free convection from heated surfaces in all its forms and over a wide range of Rayleigh number. It is noted that not all of these studies dealt with the study of the effect of the cavity ratio on heat transfer by free convection from square-shaped surfaces, which is the form that is more applied in electronic devices.

Therefore, the current research means studying the rate of change in the average of Nusselt number, which represents a function of the rate of change in the rate of heat transfer by convection, as well as studying the thermal gradient above the surface, and this was done through using three hollow surfaces in proportions (0.25, 0.5, 0.75) of the total area.

## Experimental Set-up

The Experimental Set-up used in this study and shown in Figure (1) consists of a means of fixing the surface in the horizontal state with a three-dimensional stirring mechanism, the double-spatial stirring that is used to measure the temperature over three flat hollow surfaces. Each heat exchange surface is an aluminum plate that has a shape modulus of (1) and an emissivity of (0.04) square in shape and dimensions (96mmX96mm) and thickness (9.6mm) With a square central cavity with dimensions [72mmx72mm] That is, by (0.25, 0.5, 0.75)  $m=A_h/A_t$  of the total area, as shown in Fig (24)

Each of the used plates was finely polished in order to obtain a flat surface, and each surface was perforated with eight holes with a diameter (2mm) and with an impenetrable depth of (8.8mm) With three holes in each side, as in Figure (2) and in order to measure surface temperatures, thermocouples of the type. were used (T) And that is after being calibrated and installed inside the designated holes using high temperatures (Super Glue).

The method used in the process of heating the heat exchange surfaces is represented by thin strips made of nichrome (Alloy of Nickel and Chromium) with a width of (1.28mm) and its thickness (0.07mm) It is fixed longitudinally on a layer of mica (Mica) its thickness (0.5mm) With an average separation distance of (1mm) Then it is covered with another layer of mica for the purpose of electrical insulation, and the heater is fixed on the surface using (Super Glue).

Use glass wool with thermal conductivity (0.05W/m.°C) and thickness (4cm), and a thermal conductive cork (0.024W/m.°C) with thickness (3cm) to isolate the underside of the heat exchange surfaces and the heater together, put two thermocouples at the bottom of the cork material in order to determine the heat transmitted vertically to the bottom of the surface. The heater, glass wool and cork were also surrounded by a thick wooden frame (2.3mm) This is to ensure electrical insulation.

To ensure parallel flow at the edges of the model; the heat exchange surface at the edges is surrounded by a square wooden board with dimensions (360mmX360mm) and thickness (4mm) As an extended surface, it was isolated from heat exchange surfaces using Teflon (Teflon) has a thermal conductivity of (0.36W/m.°C) And isolate it from

it with rubber silicon. Figure ( 3 ) Explain the method of isolation and the extended surface of one of the surfaces used. .

In order to provide the appropriate climate for conducting practical experiments and to reduce the influence of external factors on the surface of heat exchange, the laboratory apparatus was surrounded by a closed space of wooden walls with dimensions(220cmX160cmX200cm) In order to provide a stable state ,reduce the effect of air currents and maintain a constant room temperature, the heat exchange surface was surrounded by a closed space of nylon material with dimensions (70cmX70cmX130cm) This is after pulling the electrical power supply wires for the heater and thermocouples out of the space in order to ensure ideal test conditions for heat transfer by free convection by preventing the occurrence of any air currents as well as ensuring that the ambient temperature does not fluctuate, which was (27°C) In most readings with fluctuation did not exceed°C ± 1 During all the experiments.

Equip the heater with alternating current by means of an electrical transformer with a range of (220 - 0) volts, connected to a type voltage stabilizer.

(VOLTAC) Use a multi -purpose digital scale type (PhilipsPM2521) To measure both the voltage and current supplied to the heater with an accuracy of up to (0.01) millivolts and) 0.001 (milliamperes .The same device was also used to measure the temperatures of the heat exchange surface by measuring the voltages generated in the thermocouples, with an accuracy of up to ( 20 ) degrees Celsius..

### Test method and results

The study aims mainly to study the effect of the cavity ratio on the rate of heat transfer by free convection, by comparing the results obtained for each hollow surface with the results of the other two hollow surfaces . And each surface on both sides was fixed horizontally by means of the mounting jaws in the device used so that the surface is free from the top and the bottom . Done Measuring the temperature above the surface at the center line for each hollow surface and for four selected levels, Rayleighnumber among seven levels, in order to show the effect of the cavity ratio on the slope in the thickness of the adjacent layer generated above the hollow surface, which was its maximum slope at the outer edge . The measurements were made at the center line of the axis (x) The positive and above the outer, inner and middle edges , because through the initial practical experiments it was found that there was symmetry around the center line as well as the symmetry that included every quarter of the surface. Used for aluminum plate in addition to the central cavity.

The surface has been equipped with a constant electrical power by means of a variable voltage electrical transformer, which is connected in series with a voltage stabilizer. The surface is left for a sufficient period of time until it reaches a stable state, which ranged between (2-4) hours, depending on the equipped capacity of the heater and the cavity ratio . After reaching the stability state, the readings of the thermocouples are taken, the voltage and current supplied to the heater and the ambient temperature, as well as the measurement of the air temperature represented by the adjacent layer above the surface, and the reading of the thermocouple is taken after every-4) (3minutes of changing the height . Then this test method is repeated for another equipped power, which is represented by seven levels of the equipped power and for the other two surfaces.

For the purpose of showing the effect of the cavity ratio on the rate of heat transfer by free convection from hollow surfaces and finding the relationship of the average Nusselt number with Rayleigh number, the experimental data that we have available has been reduced from the readings for each surface and limited to the average Nusselt number and Rayleighnumber by performing the following calculations:

The supplied power of the heater can be calculated from the two readings of the supplied voltage and current i.e [9]:

$$(1) \quad IP=VI$$

By balancing the generated and lost heat energy :

$$(2) \quad Ip=Q_{Conv} Q_{cond} + Q_{rad}$$

By calculating the amount of heat transferred by radiation and conduction , [10] the heat transferred by convection was calculated:

$$(3) \quad Q_{rad}=F_{sur} \cdot \epsilon \cdot \sigma \cdot A(T_s^4 - T_a^4)$$

$$(4) Q_{\text{Cond.}} = \frac{(T_s - T_x)}{R_{\text{ins}}}$$

$$(5) R_{\text{ins}} = \left[ \frac{L_{\text{ins } 1}}{K_{\text{ins } 1}} + \frac{L_{\text{ins } 2}}{K_{\text{ins } 2}} \right] \frac{1}{A_s}$$

whereas

(6)

$$A_s = A_t - A_h$$

And through equation(2)

$$Q_{\text{Conv.}} = IP - (Q_{\text{cond.}} + Q_{\text{rad}})$$

The heat transfer coefficient average (h) can be calculated as follows:

(8)

$$Q_{\text{conv.}} = h \cdot A \cdot (T_s - T_a)$$

(9)

$$h = \frac{Q_{\text{conv.}}}{A_s (T_s - T_a)}$$

As for calculating the average of Nusselt number, it is done by relying on the difference between the outer and inner lengths(  $L_o - L_i$ ) as a distinctive length(11)

$$(10) \quad \overline{Nu} = \frac{h \cdot (L_o - L_i)}{K_f}$$

Air properties are taken at the temperature of the membrane layer)  $T_f$ , (which was calculated from the following equation.

(11)

$$T_f = \frac{T_s + T_a}{2}$$

As for Rayleigh's number, it was calculated for all surfaces as follows(12)

(12)

$$Ra = \frac{g \cdot \beta \cdot (T_s - T_a) \cdot (L_o - L_i)^3}{\nu \cdot \alpha}$$

From the two equations ( 10 , 12 ) the data became a function of two variables; only average of Nusselt number, Rayleigh number, and for the three surfaces, and by plotting the data for each surface, the values of the constants were obtained. (c,n) which govern the relationship between the mean Nusselt number and the Rayleigh number.

In order to find the temperature distribution over the hollow surface, the dimensionless difference in temperature was calculated using the following equation [13]

(13)

$$\theta = \frac{T - T_a}{T_s - T_a}$$

## Results:-

The practical experiments of the current research were conducted on the three hollow surfaces to show the effect of the cavity ratio on the change in the mean Nusselt number with the change in Rayleigh number, as well as the effect of the cavity ratio on the thickness of the adjacent layer generated above the surface and for the Rayleigh number range that ranged between  $(5.62 \times 10^5)$  Using air as a heat transfer medium.

Figure 4 shows the change of the mean Nusselt number calculated for the first hollow surface at (0.25=m) With the change in Rayleigh number and for seven levels of Rayleigh number, as we notice from the figure that increasing Rayleigh number at the same cavity ratio will lead to an increase in the average number of Nusselt. It was found through the results that the change in the mean number of Rayleigh at  $(Ra < 1.2 \times 10^6)$  It is less than the rate of change at Rayleigh is greater than this amount and the reason for this is that the decrease in Rayleigh number will generate heat exchange between the heated surface and the barrier in contact with it less than if its value was higher because in the presence of the cavity the hot air current generated inside the cavity, which increases the buoyancy force (Bouncy) At the surface, its effect increases with the increase in the Rayleigh number as a result of its high temperature and the presence of the cavity, which leads to its faster flow to the top. In order to compare the results obtained at (0.25=m) A general equation was found that governs the change in the average Nusselt number as shown in the figure (4)

Figure (5) shows the change of the mean Nusselt number with Rayleigh number at (m=0.5) We note that the increase in Rayleigh number leads to an increase in the average number of Nusselt, and that the effect of the cavity is clear, as we note the stability of the increase in the average number of Nusselt is at the level of Rayleigh number is lower than it is at (0.25=m) This is due to an increase in the cavity rate, which increases the heat exchange rate.

The equation for the change that occurs in the mean Nusselt number with Rayleigh number and by comparing it with the first surface at. has been found ( $m=0.25$ ) It turns out that there is an increase in the average number of Rayleigh of (39.6%) This, in turn, will improve the cooling rate of the surface and the reason for the increase is an increase in the value of ( $m$ ) Which increases the thermal gradient at the edges, as well as the absence of the thermal separation area.

Figure (6) shows the change of the mean Nusselt number with Rayleigh number at ( $m=0.75$ ) It was shown through the equation for this surface that the rate of increase in the average number of Rayleigh reached (78%) of its value at ( $m=0.25$ ). As for the rate of increase between the three surfaces, we notice from Figure (7) that the rate of increase between the two surfaces is ( $m=0.25,0.5$ )It is greater than the increase between the two surfaces ( $m=0.5,0.75$ )With the increase in the average number of Rayleigh with the increase in the cavity ratio.

In order to show the effect of the cavity ratio on the thermal gradient along the surface, the temperature was measured above the surface and it was found that the maximum thermal gradient is at the outer edge and for all studied levels, but the change in the thickness of the adjacent layer at the outer edge is little affected compared to other points along the surface that The change then is greater, so to show the effect of the cavity ratio and the level of heating on the thickness of the adjacent layer, the temperature distribution was drawn above the outer edge of the three surfaces and four levels of the Rayleigh number, because a small change then generates a greater change in the other points.

Figures (8,9,10,11) show the distribution of the measured temperature over the three hollow surfaces and at the outer edge of the four levels of the Rayleigh number, as shown in each figure. Figure (8) shows the temperature distribution of the three hollow surfaces at the Rayleigh number ( $5.62 \times 10^5$ ) We notice from the figure that the thickness of the adjacent layer decreases with the increase in the cavity ratio and that the rate of decrease increases with the increase in Rayleigh number.

We notice from Figure (11) which shows the temperature distribution at the Rayleigh number ( $1.67 \times 10^6$ ) The decrease in the thickness of the adjacent layer increased with the increase in Rayleigh number, where the percentage of decrease in it was at ( $m=0.75$ )Between the highest and lowest level of the rally number more than double, and this is clear by comparing the results of the two figures, (8,11) and this indicates that the increase in the cavity ratio increases the thermal gradient rate along the surface.

### Conclusions:-

The study of heat transfer by free convection from three hollow surfaces in their horizontal position with different cavity ratios and at a constant heat flux along the surface, and the main conclusions that have been reached can be summarized as follows:

1. The heat transfer by free convection increases with the increase of the cavity ratio and Rayleigh number.
2. The behavior taken by changing the average of Nusselt number in general was similar for all surfaces with the change of this increase according to the Rayleigh number and the cavity ratio .
3. The rate of increase in the average number of Rayleigh at ( $m=0.5$ ) It reached (%39.6) of its value at. ( $m=0.25$ )
4. The rate of increase in the average number of Rayleigh at ( $m=0.75$ ) It reached (%29.2) of its value at ( $m=0.5$ )and (%78) of its value at ( $m=0.25$ ).
5. The maximum thermal gradient is at the outer edge of the surfaces and the gradient rate increases along the surface with the increase in the Rayleigh number and the cavity ratio.

### Icon List

code	the meaning	units
$A_h$	Cavity space	$m^2$
$A_s$	surface area	$m^2$
$A_t$	The total area	$m^2$
$C, n$	constants	-
$F_{sur}$	surface modulus	-
$G$	ground acceleration	$m/s^2$
$h^*$	average heat transfer coefficient	$w/m^2 \cdot ^\circ c$
$I$	electric current	A

IP	Equipped capacity	W
gr	Kirchhoffnumber	-
$K_f$	Thermal conductivity of the fluid	w/m. °C
$K_{ins}$	Thermal conductivity of the insulator	w/m. °C
Li	inner length	M
$L_{ins}$	insulation thickness	M
Lo	External length	M
m	bore ratio) $A_h/A_i$ (	-
Nu	Nusselt number	-
$Q_{cond}$	Thermal energy transferred by conduction	W
$Q_{conv}$	Heat transmitted during pregnancy	W
$Q_{rad.}$	Radiant heat transfer	W
Ra	Rayleighnumber	-
$R_{ins}$	Thermal resistance of the insulator	m. °c/w
T	temperature above the surface	°c
$T_s$	surface temperature	°c
T	Ambient air temperature	°c
$T_x$	Insulator bottom surface temperature	°c
V	electric potential difference	v

**Greek symbols**

$\epsilon$	heat exchange surface emissivity	-
$\alpha$	Thermal diffusivity	$m^2/s$
$\beta$	volumetric expansion coefficient	$k^{-1}$
$\nu$	kinematic viscosity	$m^2/s$
$\sigma$	Stefan and Boltzmann constant) $5.67 \times 10^{-8}$ )	$w/m^2.k^4$

**Dimensional symbol**

$\theta$	Dimension temperature
----------	-----------------------

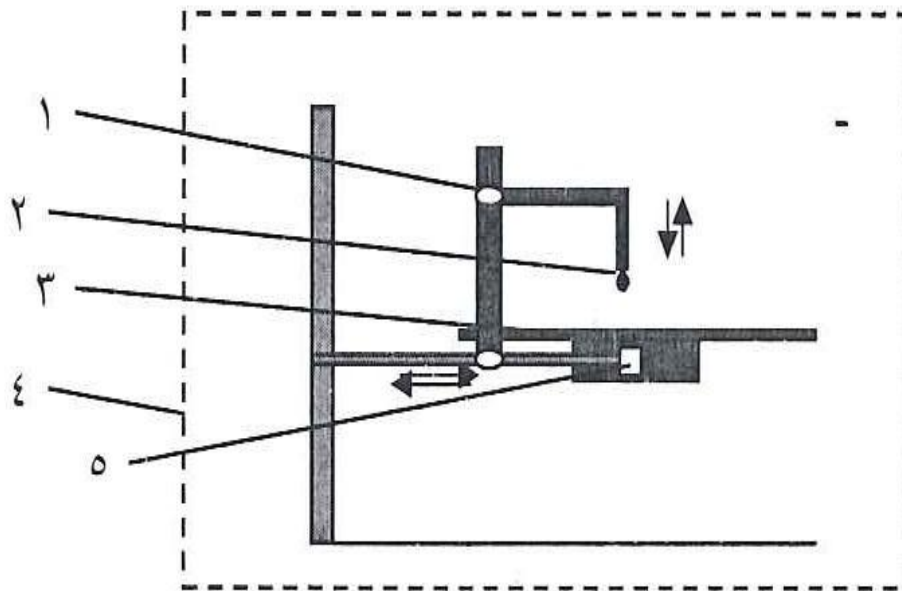

**Figure (1):-** Schematic diagram of the experimental Set-up.

1. Joint of movement in the direction of axis z
2. double space

- 3. Heat exchange surface
- 4. Nylon closed compartment
- 5. Jaws of installation

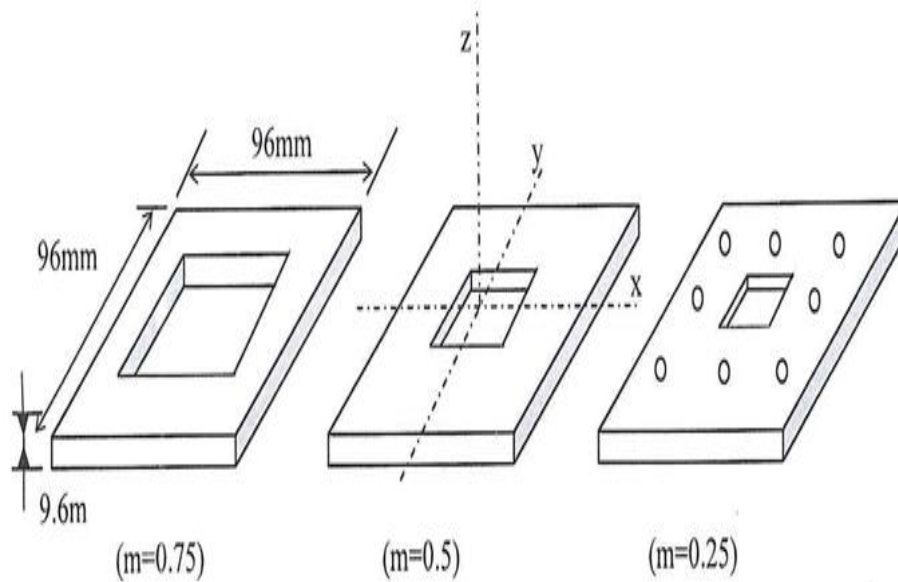

Figure (2):- Dimensions of the three aluminum sheets used with holes for thermocouples.

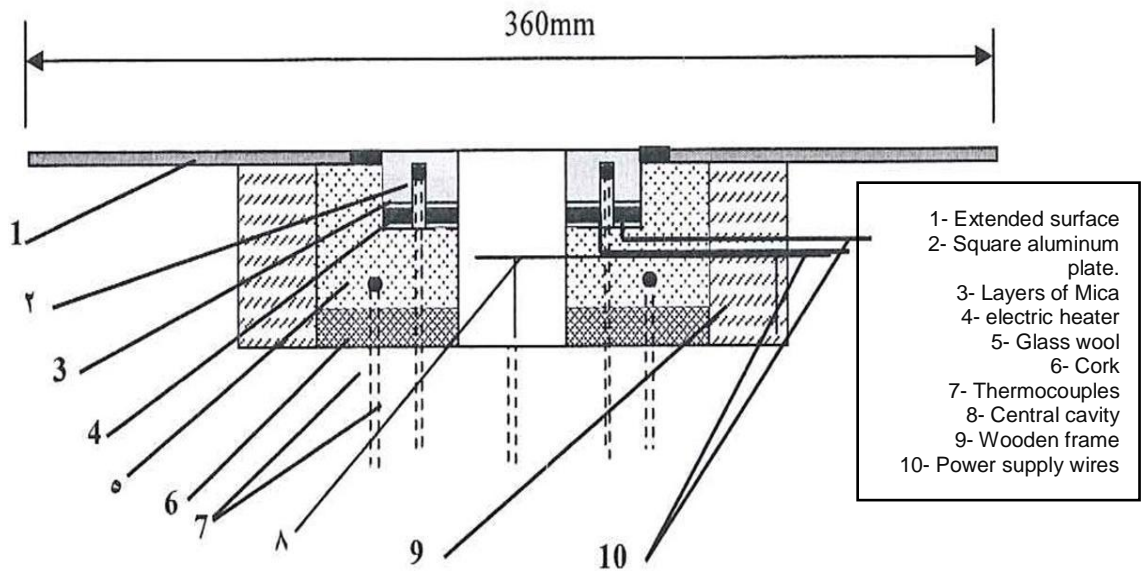

Figure (3):- A cross section showing the thermal insulation process.

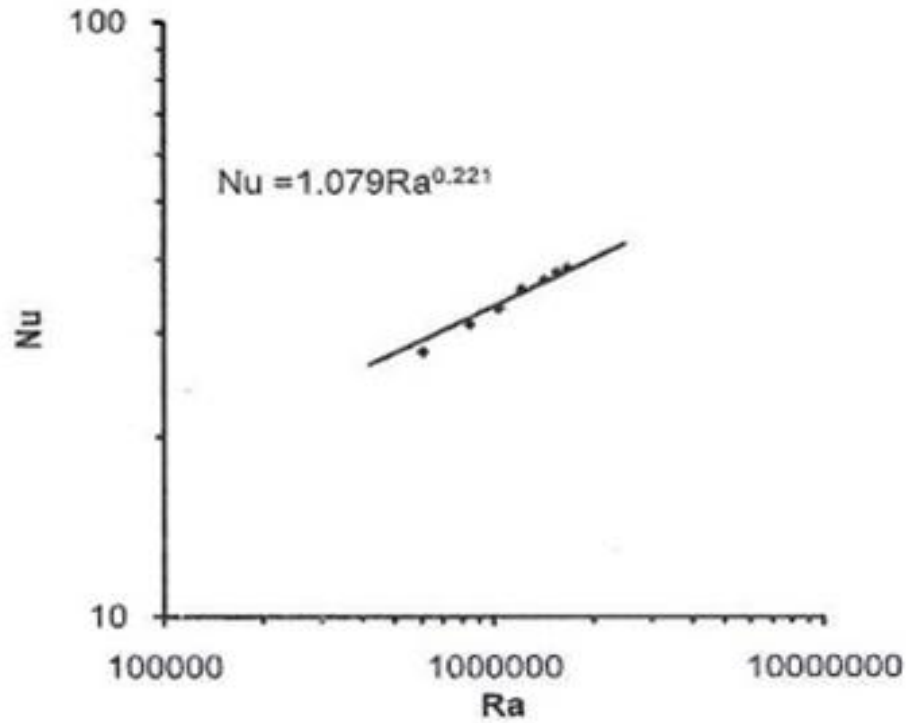

Figure (4):- The relationship between Rayleigh's number and the average of Nusselt number at )m=0.25(

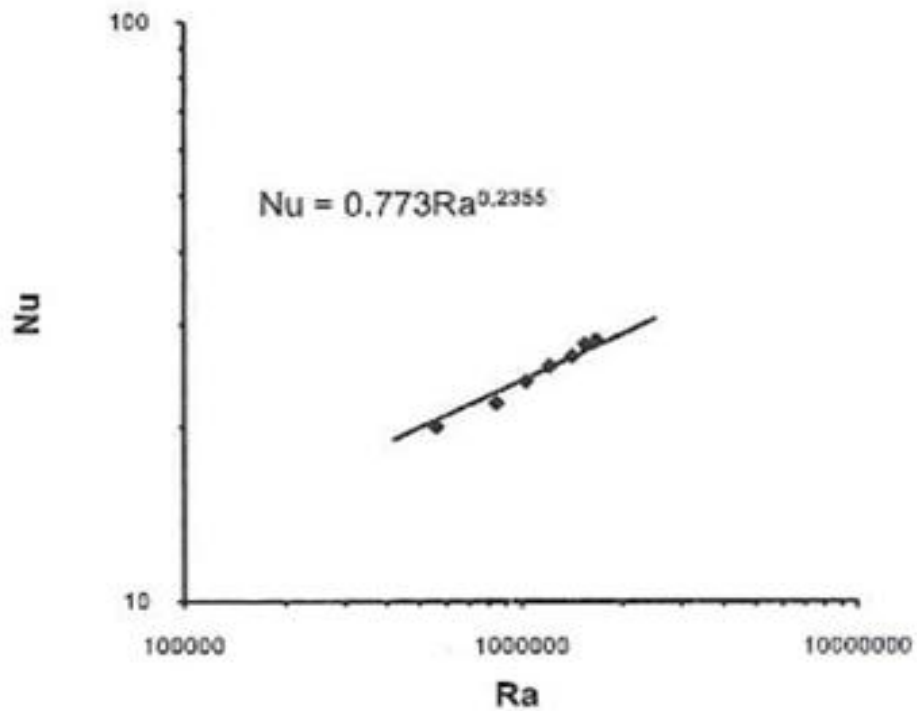

Figure (5):- The relationship between the Rayleighnumber and the average of Nusselt number at )m=0. 5(

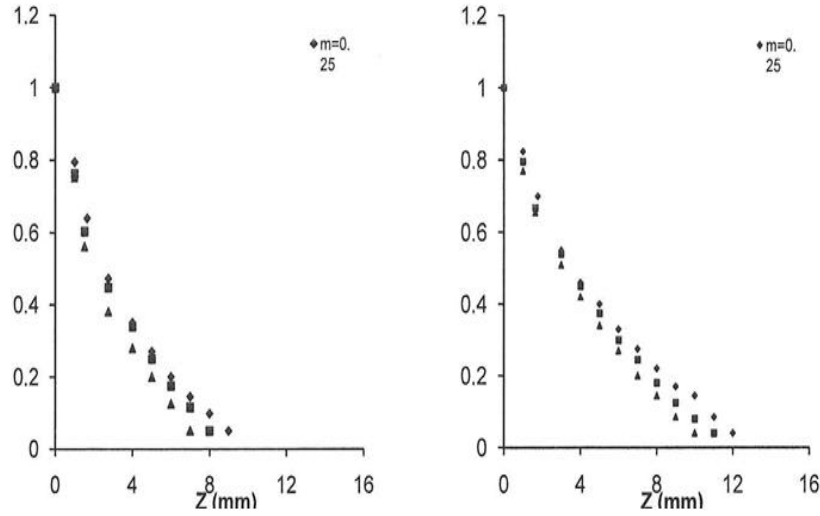

Figure (8):- Temperature distribution over the outer edge of the hollow surfaces at Ra=560000.

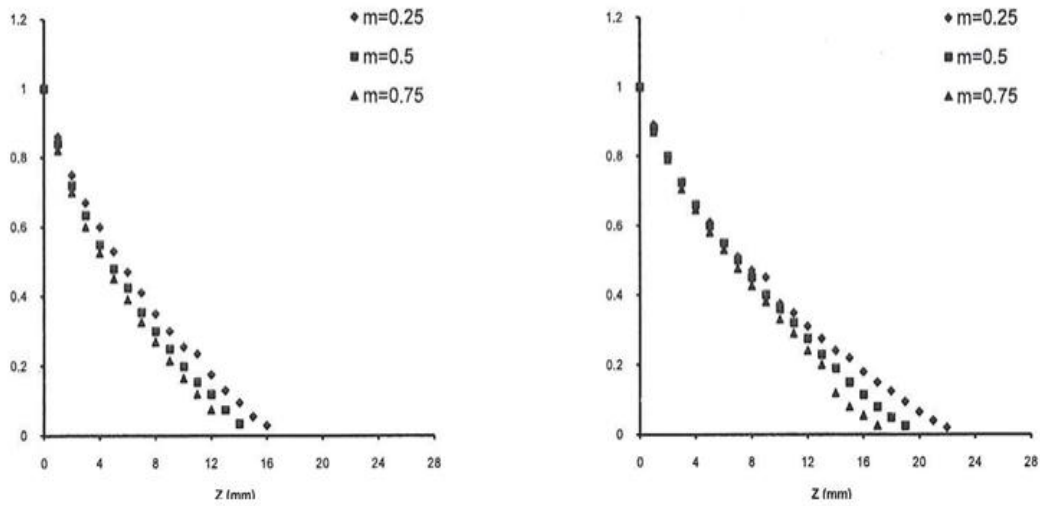

Figure (9):- Temperature distribution over the outer edge of the hollow surfaces at Ra=1033100.

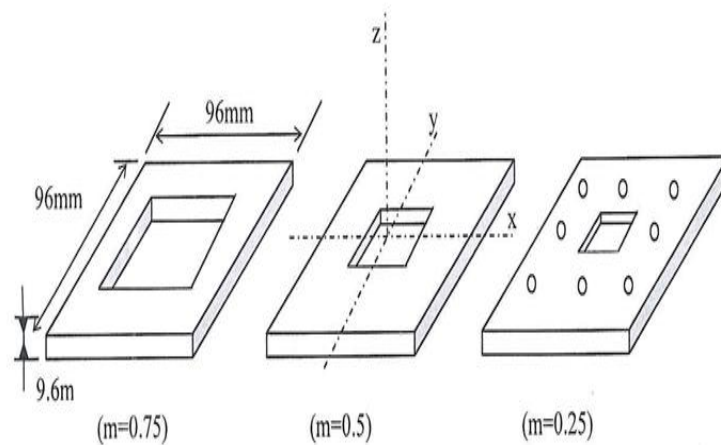

Figure (10):- Temperature distribution over the outer edge of the hollow surfaces at Ra=1422000.

**References:-**

- [1] EM arrow nd JL Gregg, "Laminar free convection from a vertical plate with uniform surface heat flux", *Trans.ASME* 78,435-440 (1956).
- [2] W.T. Kierlcus, "An analysis of laminar free convection flow and heat transfer about an inclined isothermal plate", *Int. J.Heat Mass Transfer* 11,241-253 (1968).
- [3] L.Pera and B. Gebhart, "Natural convection boundary layer flow over horizontal and slightly inclined surfaces", *Int.J.Heat Mass Transfer* 16,1131-1146 (1973).
- [4] MM Hasan and R. Eichhorn, Local "nonsimilarity solution of free convection flow and heat transfer from an inclined isothermal plate", *J.Heat Transfer* 101,642-647 (1979).
- [5] H. Shaukatullah and B. Gebhart, "An experimental investigation of natural convection flow on an inclined surface", *Int. J. Heat Mass Transfer* 21,1481-1490 (1978).
- [6] W.W. Yousef, J.D. Tarasuk and WJ McKeen, "Free convection heat transfer from upward-facing isothermal horizontal surfaces", *J. Heat Transfer* 104, 493-500 (1982).
- [7] GC Vliet, "Natural convection local heat transfer on constant-heat-flux inclined surfaces", *J. Heat Transfer* 91, 511-516 (1969).
- [8] T. Fuujii and H. Imura, "Natural convection heat transfer from a plat with arbitrary inclination", *Int. J. Heat Mass Transfer* 15,755-767 (1972).
- [9] William J. Mcguinness, Benjamin SteinJohns, Reynolds, "Mechanical and electrical equipment for buildings" sixth ed., America 1998.
- [10] Yunus, A., Cengl, "Heat Transfer A Practical Approach" McGraw—Hill (1998).
- [11] Sahraoui, M., Kaviany, M., and Marshall, H. "Natural Convection From Horizontal Disks And Rings", *J. Heat Transfer*, 110-116, 112, (1990).
- [12] Chen, TSTien, H.0 and Armaly, BF "Natural Convection On Horizontal, Inclined, and Vertical Plated With Variable Surface Temperature or Heat Flux" *Int. J. Heat Transfer*, 29, 1465-1478, (1986).
- [13] Luikov, AV, "Heat and mass transfer", USSR, Moscow, Mir Publishers 1980.